

# MICRO CONVERSION KIT



CAA USA

MCK GEN 2

# OWNER'S MANUAL



READ THE INSTRUCTIONS AND WARNINGS IN THIS MANUAL CAREFULLY AND  
UNDERSTAND THEM BEFORE USING THIS CONVERSION KIT.

Version 1.0



MICRO CONVERSION KIT

# OWNER'S MANUAL

CONGRATULATIONS ON PURCHASING OUR NEW MCK GEN 2 (MICRO CONVERSION KIT). WE TRULY HOPE YOU ENJOY THIS PRODUCT.

WE WANT TO THANK YOU FOR MAKING THE MCK THE MOST POPULAR HANDGUN CONVERSION KIT IN AMERICA. WE ARE VERY PROUD THAT THE MCK IS 100% MADE IN THE USA.

OUR MCK WAS DESIGNED TO STAND ON THREE DIFFERENT "LEGS" - LAW ENFORCEMENT, HOME DEFENSE AND RECREATIONAL SHOOTING. THANKS TO YOU, THE MCK HAS BECOME THE MOST FUN RANGE GUN ACCESSORY IN AMERICA.

OUR NEW GENERATION 2 MCK WAS DESIGNED WITH THE INPUT WE RECEIVED FROM YOU, OUR LOYAL CUSTOMERS. THE MCK GEN 2 HAS BEEN RECEIVED WITH INCREDIBLE ENTHUSIASM AND IS A GREAT ADDITION TO OUR ALREADY WORLD FAMOUS, MCK FAMILY.

WE AT CAA USA ARE CONSTANTLY SEEKING TO IMPROVE THE END USERS INTERFACE WITH OUR PRODUCTS. THE ERGONOMIC FRONT HAND GRIP ALONG WITH SPARE MAGAZINE HOLDER ARE TWO OF THE MANY ADVANTAGES WE IMPLEMENTED IN OUR MCK (MICRO CONVERSION KIT) LINE.

IF YOU HAVE ANY QUESTIONS/CONCERNS PLEASE DON'T HESITATE TO REACH OUT TO US VIA EMAIL ([INFOUSA@CAAGEARUP.COM](mailto:INFOUSA@CAAGEARUP.COM)) OR PHONE (754.205.9385)

**LTC (RET IDF) MIKEY HARTMAN**  
**CEO CAA USA**



[WWW.CAAGEARUP.COM](http://WWW.CAAGEARUP.COM)



# **ADVANTAGES OF THE MCK**

- 1. ONE MODEL FITS MULTIPLE HANDGUNS**
- 2. CAPTURED CHARGING HANDLE**
- 3. EXPOSED SLIDE RELEASE**
- 4. ERGONOMIC FRONT HAND GRIP**
- 5. SPARE MAGAZINE HOLDER**
- 6. COMES WITH EXTENDED STABILIZER BRACE**
- 7. SUBSTANTIALLY REDUCED RETAIL PRICE**
- 8. 100% MADE IN THE USA**

# MCK GEN 2 ADVANTAGES

1. NEW STABILIZER ALLOWING THE USER TO FIRE MCK WHILE IN FOLDED AND LOCKED POSITION.
2. REAR DOOR EXTENDS FURTHER BACK 15 DEGREES FOR EASE OF INSERTION AND EXTRACTION OF HANDGUN.
3. ACCOMMODATES UP TO 1.1" SUPPRESSOR HEIGHT SIGHTS.
4. FEATURING A NEW CHARGING HANDLE PROVIDING A MORE SECURE CONNECTION TO THE FIREARM.
5. COMES WITH ALUMINUM TOP PICATINNY RAIL FOR IMPROVED STABILITY, DURABILITY, AND ACCURACY.
6. ALLOWS FOR THE USE OF CAA USA'S BRASS CATCHER (SOLD SEPARATELY)
7. NEW AND IMPROVED SPARE MAGAZINE HOLDER THAT OPERATES WITH USE OF MAG CATCH/RELEASE.
8. SUPPRESSOR FRIENDLY AND ACCOMMODATES ALL SUPPRESSORS UP TO 1.38" DIAMETER.

---

Should you ever need to replace it, this manual is available FREE upon request from CAA USA or on the CAA USA website at [www.caagearup.com](http://www.caagearup.com).

## PLEASE READ BEFORE USING

READ AND FOLLOW THE MANUAL. FOR MORE INFORMATION VISIT OUR WEBSITE (WWW.CAAGEARUP.COM). MAKE SURE THE FIREARM IS UNLOADED PRIOR TO INSTALLATION. PRACTICE SAFE FIREARM HANDLING PROCEDURES AT ALL TIMES. DO NOT USE COMPENSATED HANDGUNS OF ANY KIND.

By adding a stock to a Micro Conversion Kit body, you are making it an MCKN, which is a NFA item (SBR). Please read below for all whom purchased a Micro Conversion Kit with a Stock

**NFA RULES** are the federal laws which regulates the sale and possession of certain weapons including: Machine Guns, Suppressors, Short Barreled Rifles, Short Barreled Shotguns, Destructive Devices and ADW.

**WARNING!** (From BATF RONI Classification Letter of May 06, 2010 paragraph 5) The addition of the MCKN stock set to any pistol results in the manufacture of a short-barreled rifle (SBR) which falls within the classification of firearms subject to NFA controls (Section 5845(a)(3).The manufacture of SBR's is generally lawful when performed alter the receipt of a properly submitted ATF Form I (application to make and register a firearm) and submission of a \$200.00 making tax payment. Firearm must be marked with mfg's name, city & state.

**WARNING!** (Provided by our legal counsel) If you actually possess or constructively possess, a pistol and the MCKN device, even if the pistol is not assembled into me MCKN device,the combination would constitute a short barrel rifle (SBR) which may not be lawfully possessed unless it is registered in the National Firearms Registration and Transfer Record. You are in constructive possession of an object if you have dominion and control over it whether or not you are actually handling it.

**WARNING!** (Other applicable laws) State and Local Laws supersede NFA controls. Title 27 CFR Chapter II Section 479.52. You must be over 21 years old. Export of this product is controlled by US State Dept & ITAR.

[www.caagearup.com](http://www.caagearup.com)

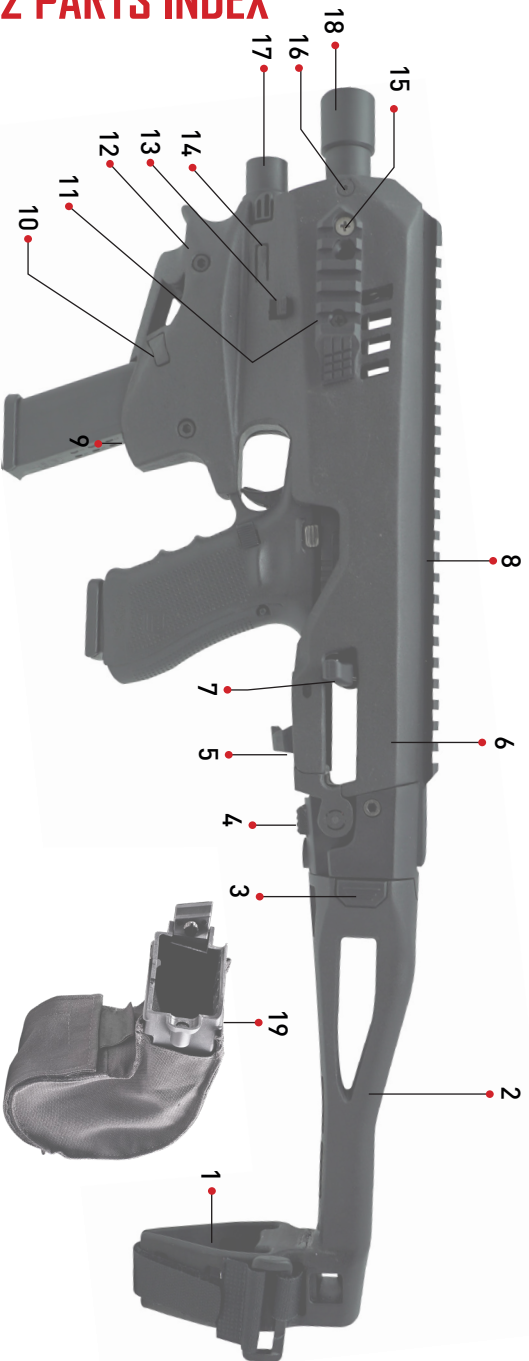

# CAA USA MCK GEN 2 PARTS INDEX

- |   |                                      |   |
|---|--------------------------------------|---|
| 1. Rubber/Polymer With Velcro Strip       | 8. Aluminum Top Picatinny Rail       | 15. Barrel Shroud Screws                  |
| 2. Side Folding Arm Stabilizer/Stock      | 9. Spare Magazine Carrier            | 16. Barrel Shroud Housing and Plug Screws |
| 3. Stabilizer / Stock Locking Push Button | 10. Spare Magazine Release Button    | 17. Polymer Flashlight Plug               |
| 4. Hatch/Door Locking Button              | 11. Picatinny Side Rail (x2)         | 18. Barrel Shroud                         |
| 5. Handgun Insertion Hatch/Door           | 12. Ergonomic Front Hand Grip        | 19. Brasscatcher (not included)           |
| 6. MCK Gen 2 Chassis                      | 13. Handgun Extraction/Framelock Tab |   |
| 7. Charging Handle                        | 14. Flashlight Release Button        |   |

# HANDGUN INSTALLATION

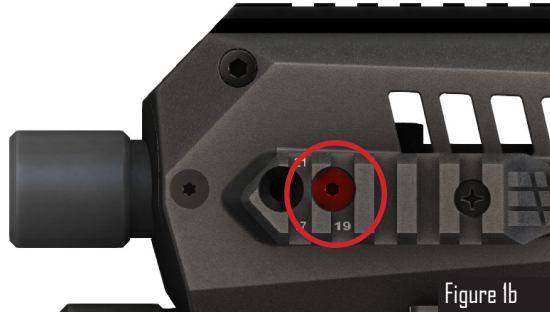

## STEP 1

The MCK barrel shroud in all models ships from the factory in the 19\* (rear) position for safety purposes. Make sure that your handgun's model appears on the side of the MCK. **Example:** First hole in the first notch of the side picatinny rail (**Figure 1a**) is for full size handguns and the second hole in the second notch of the side picatinny rail (**Figure 1b**) is for compact handguns. Otherwise, **DO NOT** try to insert the handgun into the MCK Chassis.

\*For future MCK models (Springfield, CZ, and HK), instead of the 17 it will say "F" for (Full Size), instead of the 19, it will say "C" for (compact size).

**F = Full Size C = Compact Size**

**DO NOT** use any handgun unless listed on the inner right side of the MCK!





## STEP 2

After making sure that your handgun's model appears on the MCK, set the barrel shroud to the appropriate position. To change to either fit the full-size handguns or compact handguns, you will need a 3mm Allen Wrench (provided with this kit). Loosen the screw **(2)** (Figure 2b) on both side picatinny rails. Once the screws are removed from both side picatinny rail, you can use your hand to slide the barrel shroud fully forward, so you can adjust it for full-size handguns (Figure 2a). Once done, place the screws back in the side picatinny rails in the 17 position (Figure 2a), and tighten, please do not overtighten. To change back to the 19 (rear) position, repeat these steps: Push the barrel shroud back to line up with the hole and place the screws in the 19 position (Figure 2b). If needed, use rubber mallet to tap shroud into desired 19 position.

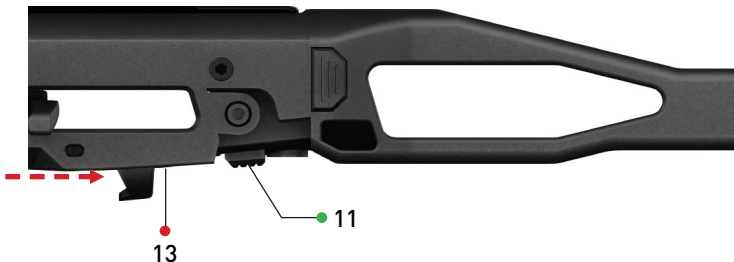

Figure 3

## STEP 3

Push and hold the locking-button **(11)**. Pull back on the insertion hatch/door **(13)** towards rear (shown above in Figure 3)

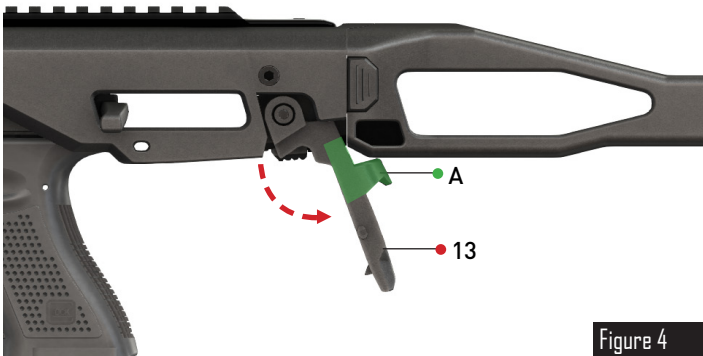

Figure 4

#### STEP 4

Using fingers on latch (A), pull down the insertion hatch/door (13) to the fully extended position (shown above in Figure 4)



Figure 5

#### STEP 5

Push back the charging handle to the most rearward position. Insert the handgun into the MCK chassis at the angle illustrated above (Figure 5) and in the direction of the arrow above. Make sure the serrations on the back of the handgun line up with the serrations on the charging handle! (12) Slide handgun in properly until it clicks in place, engaging the frame's rail system. **DO NOT PUSH FORWARD UNTIL THE HANDGUN PROPERLY SITS IN THE CHARGING HANDLE. MAKE SURE THERE IS NO SPACE BETWEEN THE REAR OF THE HANDGUN SLIDE AND THE CHARGING HANDLE. (12)**



Figure 6a



Figure 6b

### STEP 6

Following the illustration above, slide the handgun forward until the handgun extraction tab (16) clicks. To properly seat the handgun forward, make sure the muzzle of the handgun is pointed at a downward angle while sliding forward, this will allow the gun to remain level and engage the locking mechanism properly. **DO NOT MOVE ON TO THE NEXT STEP IF MUZZLE OF THE HANDGUN IS NOT STRAIGHT AND IN LINE WITH MCK BARREL SHROUD. IF HANDGUN APPEARS TO BE AT AN ANGLE, PLEASE REMOVE THE HANDGUN FROM THE CHASSIS AND REPEAT STEP 5.**



Figure 7a

### STEP 7

Close the insertion hatch/door (13) and push it forward until it clicks and locks on the locking pin (circled). Make sure that the locking button (11) fully extends out. **DO NOT OPERATE MCK UNLESS LOCKING BUTTON IS EXTENDED OUT AND CLICKS.**



Figure 8

### STEP 8

To remove handgun, first follow **STEP 3** and **4**. To unlock the handgun, pull down simultaneously the extraction tabs **(16)** from both sides, left and right **(circled)**. Only then can you slide the handgun out of MCK chassis.

---

## THUMB REST INSTALLATION



Slide the thumb rest on the Picatinny side rail. Place it in position by using the locking-tooth.

Make sure that the locking-tooth is forward and the thumb rest faces the same angle as illustrated above.

# SUPPRESSOR INSTALLATION



## STEP 1

Remove the barrel shroud screws and front assembly screws from each side Picatinny rail and from of the body with 3mm Allen wrench provided.



## STEP 2

Pull the shroud housing plug and barrel shroud out of the front of the chassis. This will allow direct access to the threaded barrel on your handgun.



## STEP 3

From here, insert the suppressor into the front of the MCK attaching the suppressor to the threaded barrel of your handgun while inside the unit.

# SUPPRESSOR EXTRACTION



## STEP 1

To take the suppressor out of the MCK, unscrew the suppressor from the threaded barrel and pull out of the chassis.



## STEP 2

Place Shroud Housing Plug and barrel back into the front of the MCK. Insert the screws to lock and retain the shroud housing plug and barrel in place. Make sure the shroud housing plug screw holes and barrel shroud screw holes are aligned and in place relative to your handgun size and tighten screws down.

# BRASS CATCHER INSTALLATION



## STEP 1

Remove the screw located in front of the ejection port with 3mm Allen wrench provided. (right side of MCK).



## STEP 2

Align the Brass Catcher with screw hole and tighten (under red circle). The Brass Catcher will now pivot to close around the ejection port. The Brass Catcher remains shut over the ejection port of the MCK with a magnet (green circle) located to the rear of the ejection port.

# EXTRA MAGAZINE CARRIER FUNCTION



The extra magazine on the MCK Gen 2 is retained by a magazine catch and magazine release button. To store your extra magazine, simply insert it into the slot in the angle following the arrows as illustrated above until you hear a positive click.



To remove the extra magazine from the MCK, press the magazine release button (circled) while pulling the handgun magazine down and out of the chassis. (see illustration above with arrows pointing down).



# ARM BRACE FUNCTION

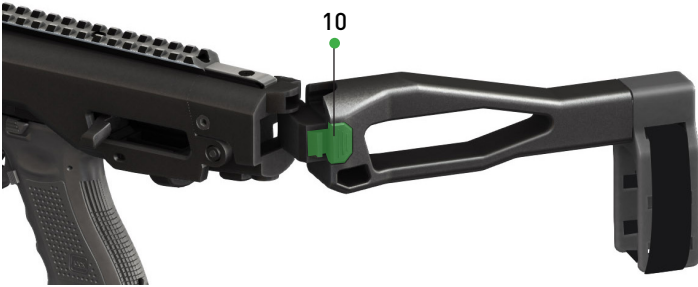

## STEP 1

FOLDING: Push the locking push-button (10) and swing the arm brace / stock on its hinge until it locks against the chassis.

\*Make sure the Velcro does not obstruct the locking-hook.



## STEP 2

OPENING: To release the stock from its locking-hook (circled red), slightly lift it and pull the stock open so the push-button (10) extends and locks.

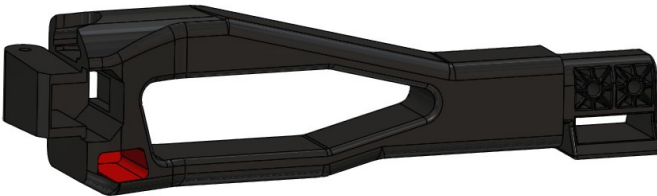

GEN 2 Stabilizers now come with a slot to put your earplugs on the go (red section) that can be secured with the earplug door.

# FLASHLIGHT INSTALLATION



## STEP 1

Push on both (left/right) locking-levers (22) and pull out the polymer sleeve (green). Do not push the pistol extraction button by mistake.



## STEP 2

By rotating the flashlight 180°, you can choose which direction the activation push button faces (left or right).

## FLASHLIGHT INSTALLATION (CONTINUED)



### STEP 3

Slide the flashlight into its slot until it locks.



### STEP 4

To replace the battery, by going through **STEP 1** (above), unscrew the butt cap. Flashlight uses a single CR123 battery.

**ENJOY & STAY SAFE**

**MICRO CONVERSION KIT**



CAA USA | [www.caagearup.com](http://www.caagearup.com) | (754) 205-9385